



UHF RFID READER SHORT RANGE READER BLUEBOX

PRODUCT DESCRIPTION

The UHF Short Range Reader BLUEBOX with internal antenna is an UHF read and write RFID device operating in the 840 MHz to 960 MHz frequency band and suitable for industrial application.

It communicates with a 'host' system (typically a PC or a PLC) through a RS232 / RS485 serial line. Optionally the UHF Short Range Reader BLUEBOX is available with a CANbus (SAE J1939 or CANopen), USB VCP or USB HID interface.

The UHF Short Range Reader BLUEBOX acts as a joint through a set of commands between the host system and one or more RFID transponders (or tags) present near the antenna.

The same 'master/slave' protocol is used for the communication between the host system ('master') and the BLUEBOX ('slave'), independently of the kind of connection (point to point or multipoint).

Through these communication channels, it is also possible to configure the functional parameters and to upgrade the firmware, the 'BLUEBOX Show' software of the SDK is foreseen to explicate these operations.

BLUEBOX is designed and developed to allow installation and maintenance experts to perform all power supply and communication connections without the need to open the device.

► APPLICATIONS

- Parking Automation
- Logistics
- Robotics
- Data Collection

► FEATURES

- Integrated Antenna
- Upgradeable FW
- M12 Connector
- RS232/RS485
- Optional: CANbus (SAE J1939 or CANopen), USB VCP or USB HID
- IP65 Protection Class

► RFID OPTIONS

- UHF (EPC C1 GEN2 / ISO 18000-63)

TECHNICAL DATA

ELECTRICAL SPECIFICATIONS	
Power Supply	10 ... 36 Vdc
Power Rating	4 W @RFout = 27 dBm
Operating Frequency	865 – 868 MHz (ETSI) 902 – 928 MHz (FCC) - on request
Max. Power	Max 500 mW (+27 dBm), software configurable in 1 dB steps
Input Sensitivity	-51 dBm ... -87 dBm, software programmable in 1 dB steps
Operating Distance	up to 3 meters*
Antenna	Integrated
Antenna Gain	3.4 dBic
Antenna Beamwidth	115°
Antenna Axial Ratio	< 3 dB
Antenna Bandwidth	18 MHz
Status	1 LED, Buzzer
Interfaces	Serial RS232 RS485 Optional: CANbus (SAE J1939 or CANopen), USB VCP or USB HID
Connections	1 M12 Connectors (5-poles A-coded male for power supply and serial interface)
MECHANICAL SPECIFICATIONS	
Dimensions	120 × 122 × 37 mm
Material	Plastic, ABS (Acrylonitrile Butadiene Styrene)
Weight	400 g
Protection Class	IP65

ENVIRONMENTAL CONDITIONS	
Operating Temperature	-20 °C to +55 °C
Storage Temperature	-40 °C to +85 °C
Humidity	up to 95 %, non condensing
SUPPORTED STANDARDS TAGS	
Standard ISO 18000-63 (EPC Class 1 Generation 2) E.g.: Alien Higgs 2/3/4, Impinj Monza, NXP UCODE, etc.	
APPLICABLE STANDARDS	
EMC	EN 301489-1:2012-04 (v1.9.21) EN 301489-3:2013-12 (V1.6.1)
Radio Regulation	EN 300330-1:2015-08 (V1.8.1) EN 300330-2:2015-08 (V1.6.1)
Safety	EN 60950-1:2014-08 EN 62369-1:2010-03 EN 50364:2010-11
RoHS 2	EC Guideline 2011/65/EU and amendment 2015/863/EU, updated by 2017/2102/EU EN 50581:2012 (valid till 2024-07-07) EN 63000:2018
REACH	EU Guideline 1907/2006, updated by 2020/171/EU
Certificate	FCC, CE
SDK INFORMATION	
Supported OS	Windows 7, 8
Supported Languages	C#, C++, serial command protocol

*Reading distance depends on tag, antenna and environmental conditions

APPLICATION EXAMPLE

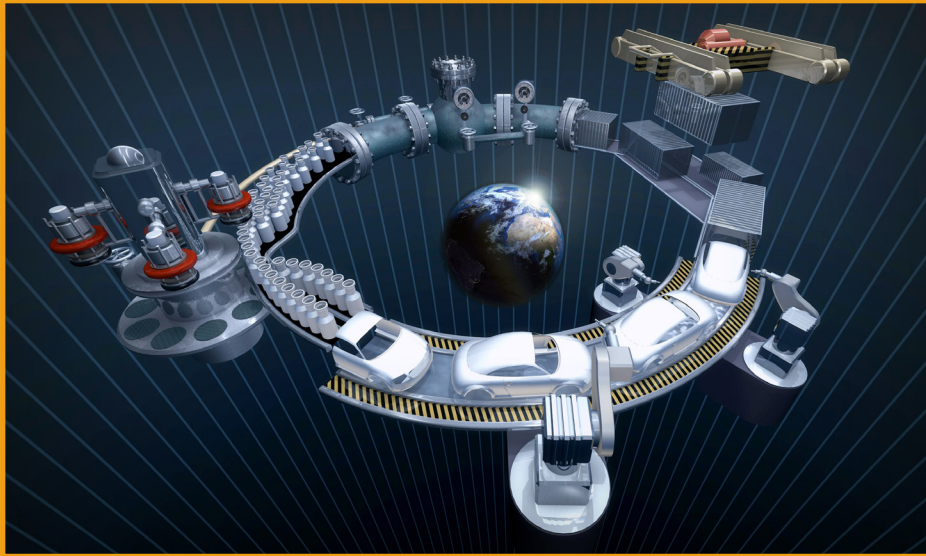

AUTOMATED VEHICLE PRODUCTION

The **UHF Short Range Reader BLUEBOX** is ideal for industrial 4.0 automation processes in automotive production. The different production steps within a manufacturing process require robust and flexible devices that can be easily integrated.

The **UHF Short Range Reader BLUEBOX** may be optimally integrated into this process thanks to its compact design. The production of an automobile comprises an integrated process, having different requirements at each production step. From the foundry to the paint shop, high temperatures require the use of heat-resistant equipment. Thanks to its IP65 protection class, the **UHF Short Range Reader BLUEBOX** is ideally suited for this purpose. The reader can **withstand temperatures from -40 °C up to + 85 °C** without any problems.

The reader can be easily mounted through prefabricated drill holes - even outside the production line. Thanks to the **large 3-meter reading range**, the parts can be assigned contact-free within the chassis production up to the exterior equipment.

The material flow within the production of a motor vehicle requires flexibility and robustness. The **UHF Short Range Reader BLUEBOX** can be used to optimally allocate the various variants. The detection of several screws or threads is guaranteed by bulk detection.

MECHANICAL VIEW

All Dimensions in millimeters (mm)

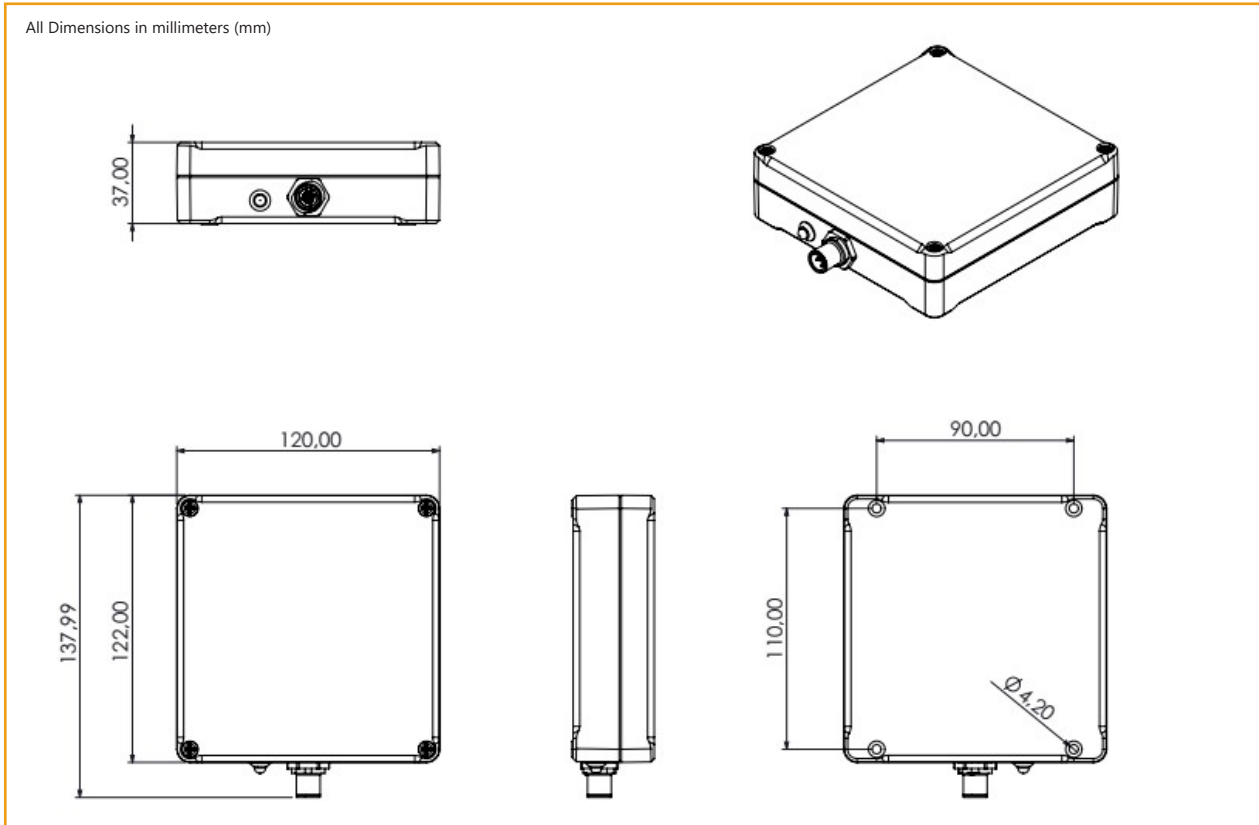

ORDER CODES

VERSIONS	ORDER CODES
UHF Short Range Reader BLUEBOX - RS232/RS485	R-IN-UHF-5721U
UHF Short Range Reader BLUEBOX - USB VCP	R-IN-UHF-5721U-USB
UHF Short Range Reader BLUEBOX - USB HID	R-IN-UHF-5721U-HID
UHF Short Range Reader BLUEBOX - SAE J1939	On Request (MOQ: 20 Units)
UHF Short Range Reader BLUEBOX - CANopen	On Request (MOQ: 20 Units)