



ID Gate 7700

Date: January 2024

Version: ID Gate 7700



Please read and follow the installation instructions before operating the device and keep the instructions for future reference or for use after troubleshooting.

Table of Contents

1. Product Instruction and Structure	3
1.1 Note.....	3
1.2 Functional features	3
1.3 Technical parameter	4
1.4 Tripod turnstile mechanical system	4
1.5 Tripod turnstile electric control system.....	5
1.6 Operating principle of the system.....	5
2. Installation Instructions.....	6
2.1 Installation suggestion:	6
3. Turnstile Setting and Connections	8
3.1 Turnstile connections	8
3.2 Button introduction.....	8
3.3 Menu setting	9
3.4 Parameter setting instruction.....	9
4. Product Maintenance	11
4.1 Maintenance	11
4.2 Tips and Troubleshooting	11
5. Safety Instructions	12
6. Support	12

1. Product Instruction and Structure

1.1 Note

- Before installation, operation or maintenance, please turn off the power.
- Please do not change the inside wiring, take a photo before any disconnection.
- Do not use the power supply inside the turnstile to connect another third-party device.
- The turnstile should not be operated during thunderstorms or lightning strikes, as this may damage the electrical parts of the turnstile.

1.2 Functional features

- Compact and cost-effective security solutions
- Stainless-steel body
- Access control system. (e.g.: RFID, QR-Code and barcode reader)
- In case of an emergency, the turnstile will automatically open and allows for free passage.
- Anti-tailing function: only one person passes at a time.
- Anti-impact function: The rotating rod will lock automatically when the opening signal is not received.
- Working way: Single directional or Bi-directional
- LED indicator (red means no entry; green means entry; blue means normal close)
- Easy to install and maintain

1.3 Technical parameter

Item	Description
Frame	304 Stainless Steel with Rubber Seal
Dimensions	1200mm x 230mm x 980mm (L x W x H)
Weight	50kg
Pass Width	1 lane, 550mm (Arm length: 500mm)
Power consumption	20W
Working environment	Indoors or outdoors, IP65
Working temperature	-15°C – 60°C
Humidity	9 ~ 95% (no freeze)
Control interface	Dry contact / Relay signal
Opening time	0.2 seconds
Passing speed	35~40 persons / min

1.4 Tripod turnstile mechanical system

The turnstile's mechanical system is divided into a frame and a movable part. The frame includes direction indicators and read-write device. The main components of the movements are the motor, the motor frame, the drive shaft and the arms.

Movement structure

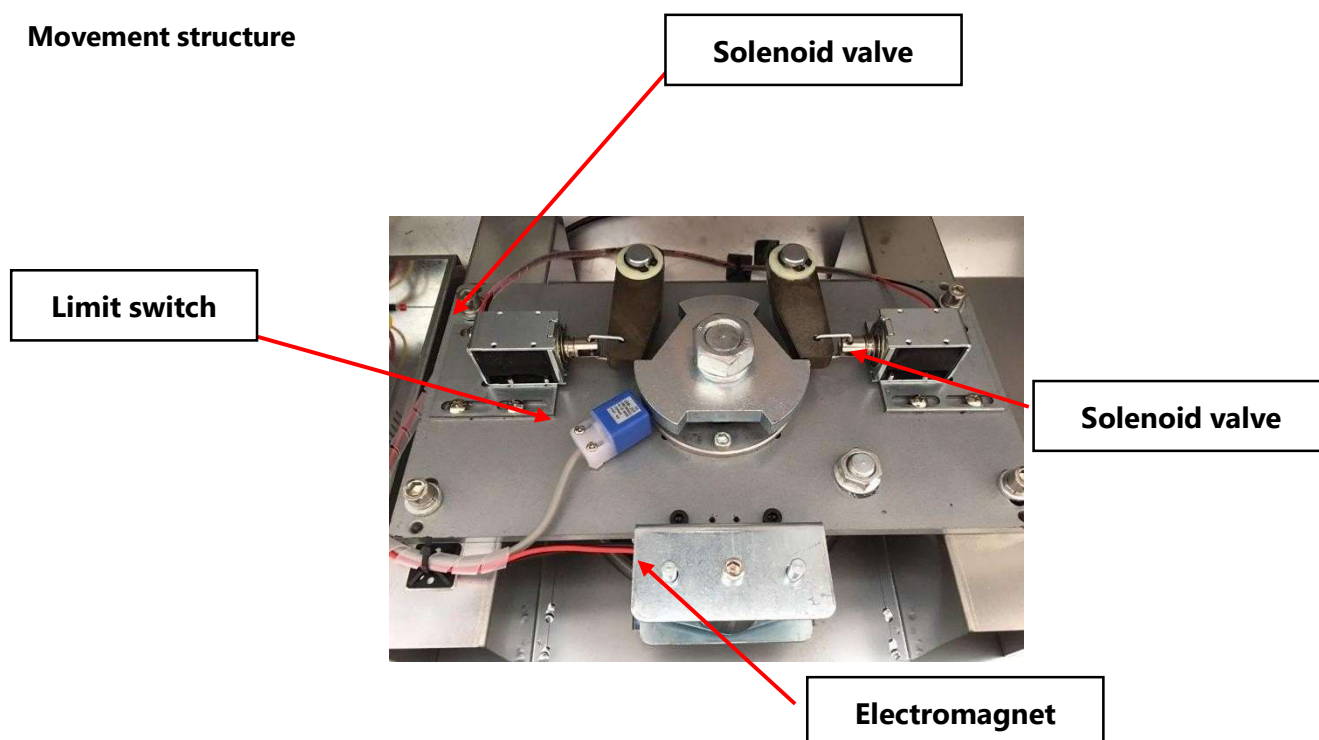

Figure 1

1.5 Tripod turnstile electric control system

The electronic control system consists of a card reader, the main control board, the direction indicator board, the transformer and so on.

Card reader (self-provided): After reading the card's information and processing the information, the card reader will send an application pass signal (switch signal) to the main control board.

Main control board: The system's control, which receives the signals from the card reader, processes these signals and then issues execution commands to the flashing light, the motor, the counter, and the alarm.

Direction indicator light: Display the status of the passage signs and guide pedestrians through the gate in a safe and orderly manner.

No.	Name	FUNCTION
1	Control board	The system's control, which receives the signals from the card reader, processes these signals and then issues execution commands to the flashing light, motor, counter, and alarm.
2	Direction Indicator	The directional indicator light shows the status of the passage sign and guides pedestrians through the gate
3	Limit switch	Check opening and closing position
4	Switch	Supply power to control board

1.6 Operating principle of the system

- a) After 3 seconds, the system will enter a working state if you turn on the power.
- b) When the card reader detects a valid card, it sends the data to a backend system for evaluation. If the card is approved, the backend system sends a signal back to the main controller.
- c) The main control receives the signals from the card reader. After thorough processing, it sends effective control signals to the direction indicator and motor, so that the direction indicator sign turns into the green arrow pass sign.
- d) If a pedestrian forgets to read his card or reads an invalid card and enters the gate, the system will forbid the pedestrian to pass through. Rereading a valid card allows passage.

2. Installation Instructions

2.1 Installation suggestion:

Note: During installation and construction, relevant circuits should be completely disconnected. Please check all connections and correct installation before applying power.

- 1) It is recommended to lay the cables 60 mm deep, at least 50 mm, into the ground.
- 2) For outdoor installations of turnstiles, it is recommended to secure them using anchor bolts embedded in concrete, with a depth ranging from 100 to 200 mm.
- 3) All assembly operations should be carried out with the power off.
- 4) The Power cable and other signal cables are carried in a 3/4" PVC pipe and buried in cement in the appropriate place.
- 5) Set up the devices in the correct position.
- 6) After the hole's position has been determined, drill the holes, and insert the anchor bolt or expansion screw M12.
- 7) Open the casing, select one of the units as a reference (preferably the middle one), align the hole of the bottom screw with the corresponding anchor screw and pre-tighten the nut.
- 8) Connect the power line and the control line according to the wiring diagram and connect the ground cable to the system.
- 9) Check the main wiring according to the wiring diagram, check that the power wiring and other wiring of the entire unit are correct, and then adjust the power after confirmation.
- 10) After the installation is complete, check the connection condition of the earth wire, connector assembly for the connecting line and all moving parts with the device. Make sure the connection is firm in order to prevent failure caused by long time operation. If any screw or part is not tightened, please tighten.
- 11) After the check of the unit status has proceeded normally, the function can be tested.

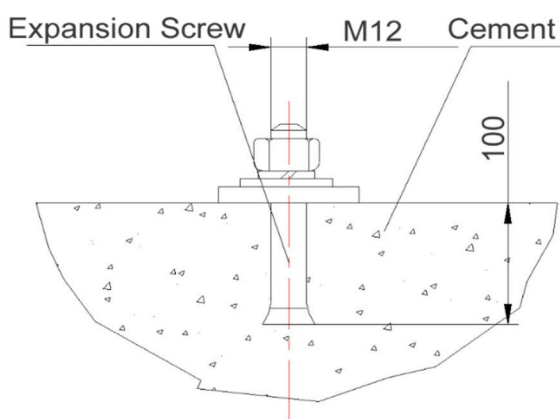

Figure 2

Drawing of the assembled anchor bolts

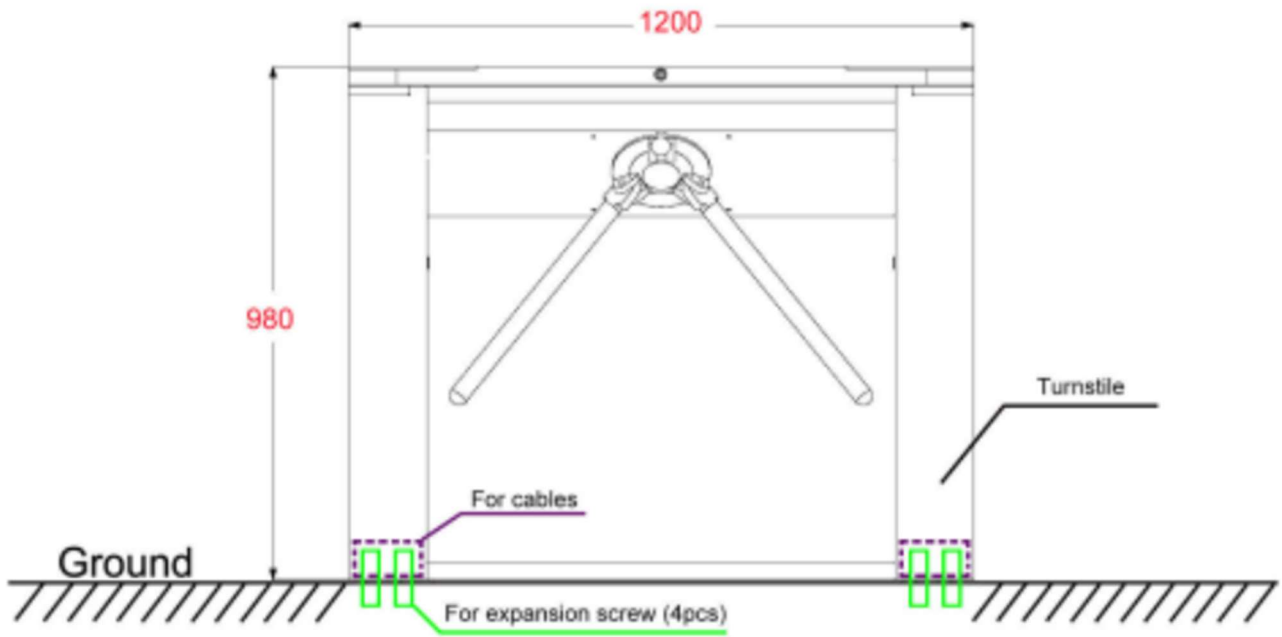

Figure 3

Position of the mounting frame/drill holes

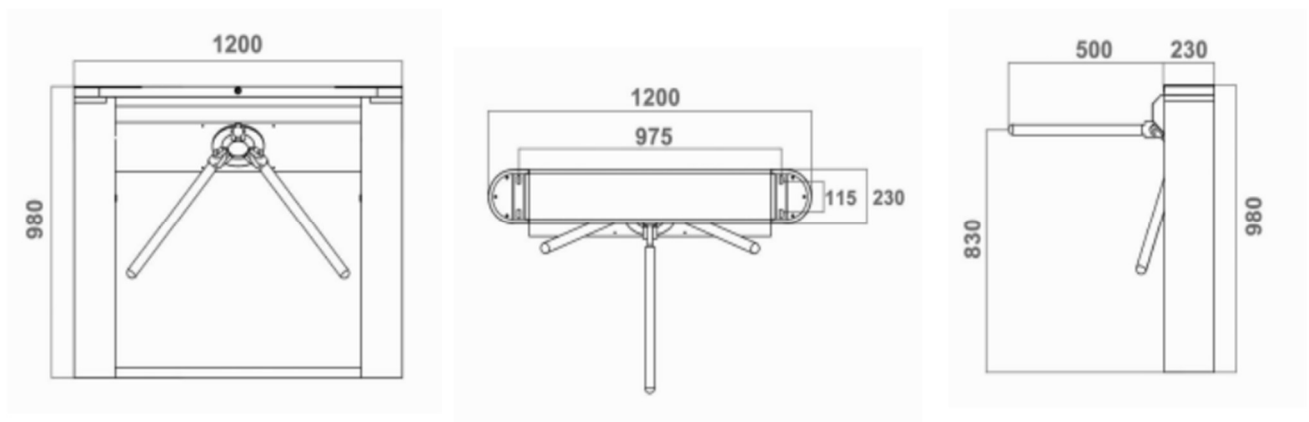

Figure 4

Product Dimensions

3. Turnstile Setting and Connections

3.1 Turnstile connections

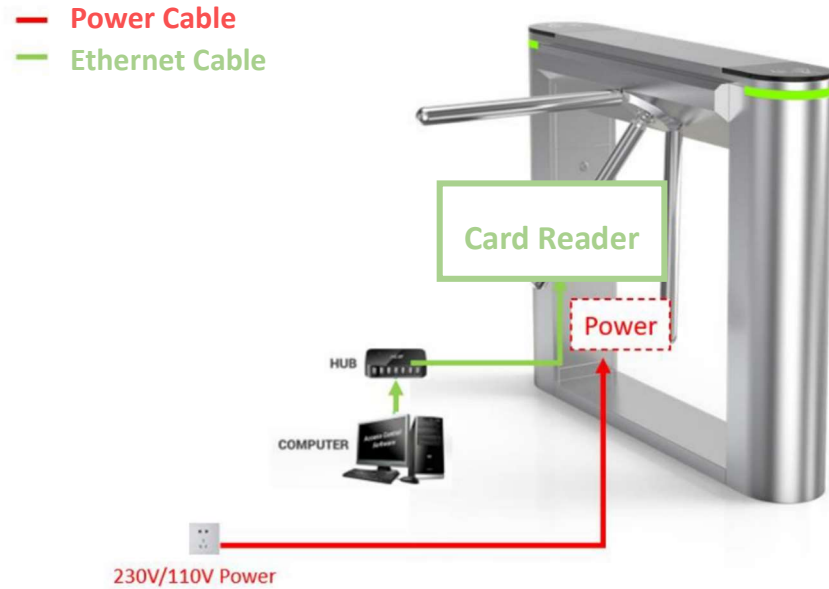

Figure 5

Position of the mounting frame/drill holes

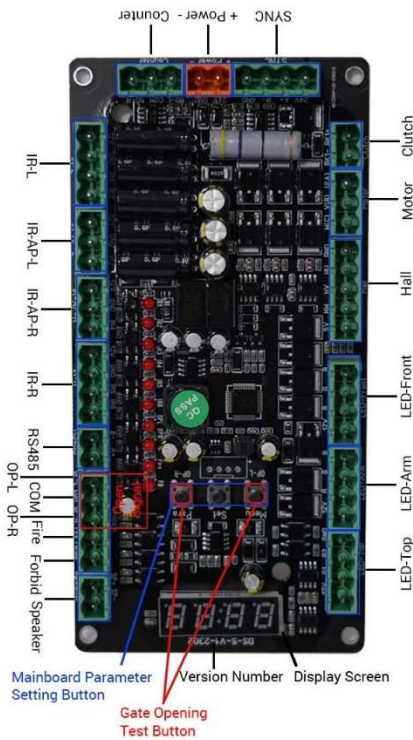

Figure 6

Description of the Main Board

OP-L = open left

OP-R = open right

Fire = Emergency Exit Connection

Red/blue masked Button =
Setting/ Testing of Parameters

Performance +/- = Power Connection 230V

Counter = Up/Down Counter for External Use

*Connect the turnstile to a 110V/230V power supply.

*Any type of third-party access control device can be connected to the "OP-L"," COM" and "OP-R" terminals.

3.2 Button introduction

The control board has three operation buttons: "MENU" menu key/confirm key, "INC" up/add key, and "DEC" down/subtract key.

"Menu" key:

1. In standby mode, it acts as a menu key. Long press this key to enter the menu.
2. In the menu interface, it acts as a confirm key. After selecting the corresponding menu, press this key to enter the menu parameter setting interface.
3. After the menu is set, press this key to save the parameters and return to the system menu interface. **"INC" key:** It increases the value by 1 when selecting the system menu and setting parameters. **"DEC" key:** It decreases the value by 1 when selecting the system menu and setting parameters.

Note: In the system menu and menu setting interface, if there is no button operation within 5 seconds, the system will automatically exit the menu to the standby interface.

3.3 Menu setting

For example, if you want to change the gate channel passage time:

Step 1: Long press the "MENU" key to enter the system menu, use the "INC" and "DEC" keys to select the "F 0 X" menu (menu explanation below).

Step 2: Press the "MENU" key to enter the channel time setting interface.

Step 3: Use the "INC" and "DEC" keys to increase or decrease the parameter value.

Step 4: After setting is complete, press the "MENU" key to save.

Step 5: Exit the menu: Select the "F 11" menu and press the "MENU" key to manually exit the menu or automatically exit the menu if there is no button operation within 5 seconds.

3.4 Parameter setting instruction

"F01" Set the passage time:

The time is automatically cleared to zero after the person passes through the gate within the set time. If no one passes through, the gate will automatically close when the time is up. (Default 5 seconds)

"F02": Constant open function setting.

- 1: Open the left electromagnet when it is always open.
- 2: Open the right electromagnet when it is always open.
- 3: Open both left and right electromagnets when it is always open. (Default value 3, open both electromagnets when it is always open)

"F03": Gate working mode.

0: Free passage (commonly used for turnstile); 1: Power-off drop bar (default 1 power-off drop bar)

"F04": Memory function.

Turn on or off the memory function of the opening signal input. Generally used for card swiping to open the gate. If there is one person swiping the card and has not passed through, whether to remember the card swiping of other people. "Prohibited" means that the second person's card swiping is effective only after the first person has passed through; "allowed" means that the number of people swiping the card is allowed to pass through continuously. (Default value 0, memory prohibited)

"F05": Repeatedly switch the gate test, mainly used to test the stability of the gate control board and aging test. Note: In the test mode, press the MENU key to exit the test.

"F06": Zero signal setting.

0: Close the gate immediately when the zero signal is detected (standard mode for three-roller gates, the main board is set to 0 by default);

1: Detect the zero signals, and then wait for the zero signals to disappear before closing the gate (commonly used for full-height gates) (default value 0)

"F07": Gate constant open setting the unit is seconds.

This parameter is used to detect continuous opening signals. When the duration of the continuous opening signal exceeds the parameter set, the system enters the constant open state (which electromagnet is always open is determined by the F02 parameter. The default value of F02 is that both electromagnets are always open). If the opening signal given to the gate is a continuous signal, the gate will remain open. After the continuous signal is disconnected, the gate will return to the standard mode. (Default parameter 0 seconds, constant open is closed)

"F08": Gate opening delay.

This parameter is effective only when the memory function is turned on. When there are too many people passing through continuously, this function can prevent the gate from opening again when the previous person has not passed through the channel. (default value 0, no delay)

"F09": Limit count setting.

Set how many times the limit signal needs to be detected during the gate opening process to close the gate. (default 1 time)

"F10": Restore factory settings.

All parameters of the main board are restored to the factory settings.

"F11": Exit the menu.

Or automatically exit if there is no button operation within 5 seconds.

Note: In free passage mode, whether to count depends on the F02 parameter. When the F02 parameter is 1, the left free passage is counted, when the F02 parameter is 2, the right free passage is counted, and when the parameter is 3, the free passage is not counted.

4. Product Maintenance

4.1 Maintenance

1. To avoid the risk of an electric shock, always turn off the device before inspecting its internal components.
2. We recommend inspecting/checking the gate regularly to ensure proper operation.
3. The material is made of stainless steel; please use appropriate cleaning agents.
4. Clean fingerprints or stubborn stains with soapy water or alcohol, rinse with cleanwater and wipe dry if necessary.

4.2 Tips and Troubleshooting

1. If the arm does not open after swiping the card, please double-check that all wires are properly connected and that the card is recognized as "valid" by our backend system.
2. If the display does not light up or shows an incorrect direction, please contact us to check for faulty wiring.
3. If the gate does not open automatically after turning off the power, the battery may be defective - please contact us for a replacement.

A) Tripod turnstile stays closed after a card has been swiped.

- a) Check whether the main board receives the opening signal.
- b) Check whether the opening signal lead or the solenoid valve lead is loose.
- c) Measure with a multimeter whether there is a voltage of 24 V on the solenoid valve terminal of the main board and assess whether the solenoid valve is damaged.

B) Tripod turnstile arms do not fall down in case of power failure.

- a) Check if the support of the electromagnet is loose, readjust it and fix it

C) When the arm is connected to the power supply, it cannot be lifted manually.

- a) Check if the pole drops support of the electromagnet is lose, test if the electromagnet is magnetic with a metal object.
- b) Use a multimeter to measure whether the main board has normal voltage output.

D) The main board is not supplied with power after switching on

- a) Check with a multimeter to check whether there is 24 voltage input at the input port.
- b) Check whether the fuse has blown.
- c) Check whether there is 24V at the output end and assess whether the power supply is damaged.

5. Safety Instructions

- 1) Turn off the power before installation, maintenance, or repair.
- 2) Do not alter the internal wiring without prior consultation.
- 3) For your own safety, have changes to the wiring or repairs to the electronic parts of the gate performed only by professionals. Also, please note that the warranty will be immediately expire if you make changes to the internal wiring, etc., without consulting an iDTRONIC employee.
- 4) Do not use the built-in power supply to connect external devices unless instructed to do so by an iDTRONIC employee.
- 5) Do not operate the gate during thunderstorms and lightning to avoid damage to the electrical components of the gate.

6. Support

iDTRONIC

Ludwig-Reichling-Straße 4

67059 Ludwigshafen am Rhein



Support@idtronic.zendesk.com